

國立臺北科技大學九十五學年度研究所產業碩士專班招生考試

系所班別：電機工程系電力電子產業研發碩士專班

120 基本電學 試題

填准考證號碼

--	--	--	--	--	--

第一頁 共二頁

注意事項：

1. 本試題共 8 題，配分共 100 分。
2. 請標明大題、子題編號作答，不必抄題。
3. 全部答案均須在答案卷之答案欄內作答，否則不予計分。

1. Please find the forced responses of v_1 and v_2 in the circuit of Fig. 1. 15%

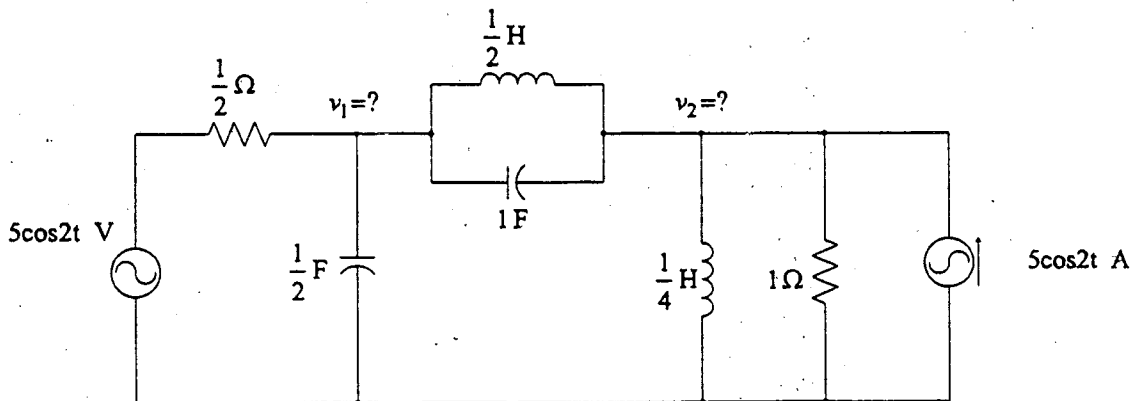

Fig. 1

2. Please determine i and v for $t > 0$ in the circuit of Fig. 2, provided the network is in a dc steady-state at $t = 0^-$ with the switch open. 15%

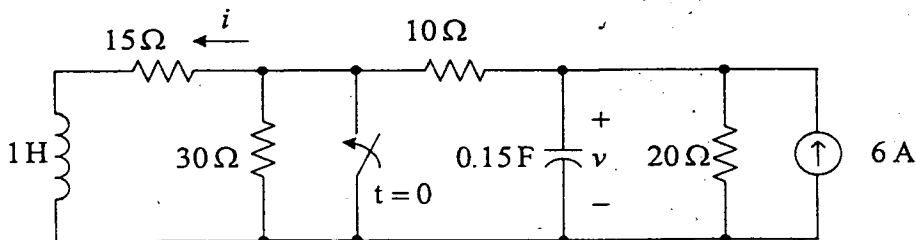

Fig. 2

3. Please design a simple peak rectifier and diagrammatically illustrate the source voltage and current of this rectifier and the influences of the capacitance. 10%
4. Please design an n-input summing circuit with the ideal operational amplifier and derive the relationship between the output signal and the input signals. 10%
5. Please diagrammatically illustrate the continuity of flux. 10%
6. Please determine the load voltage v_L , the power delivered to the diode, and the efficiency of the circuit shown in fig. 6. 10%

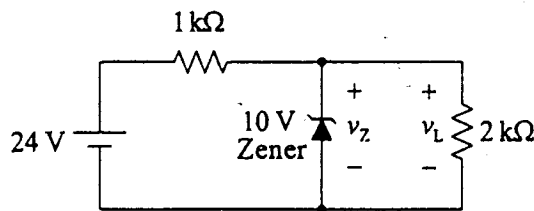

Fig. 6

7. Please find the transfer function of the system shown in Fig. 7. 15%

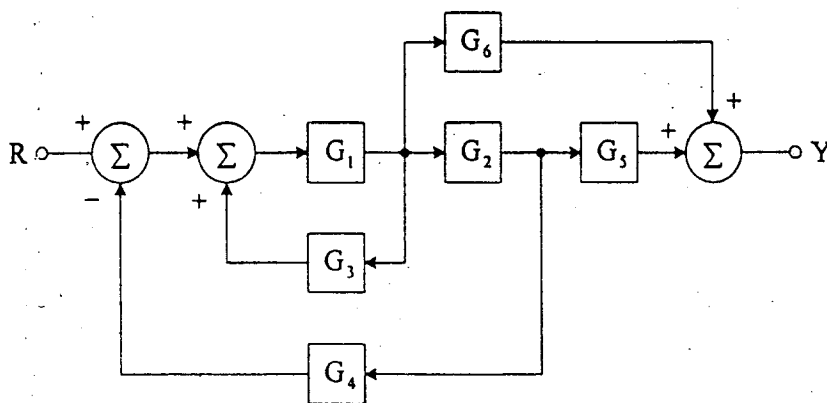

Fig. 7

8. Please analyze the operation of the +12 voltage power supply shown in Fig. 8 connected to a load drawing 400 mA, including the ripple factor of the filter capacitor C_1 , the minimum voltage of v_{in} , and the efficiency, wherein $C_1 = 470\mu\text{F}$ and $C_2 = 0.01\mu\text{F}$. 15%

注意：背面尚有試題

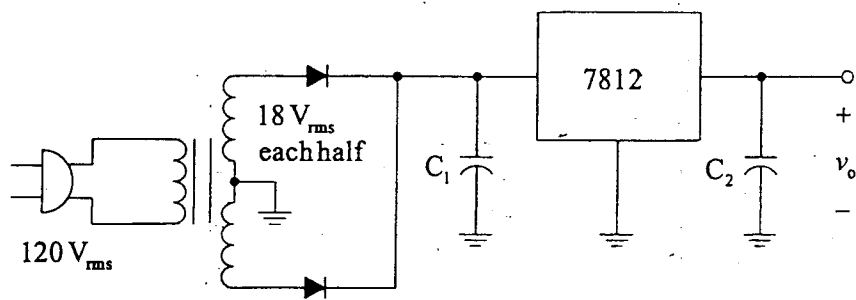

Fig. 8